

# specifications

FOR THE

# Thomas

by HEATHKIT®

*Pioneer And World-Leader in Electronic Kits*

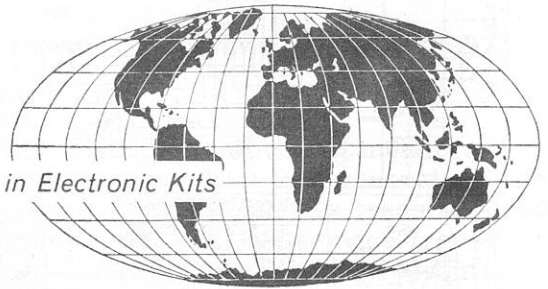

## TRANSISTOR ELECTRONIC ORGAN

MODEL GD-232

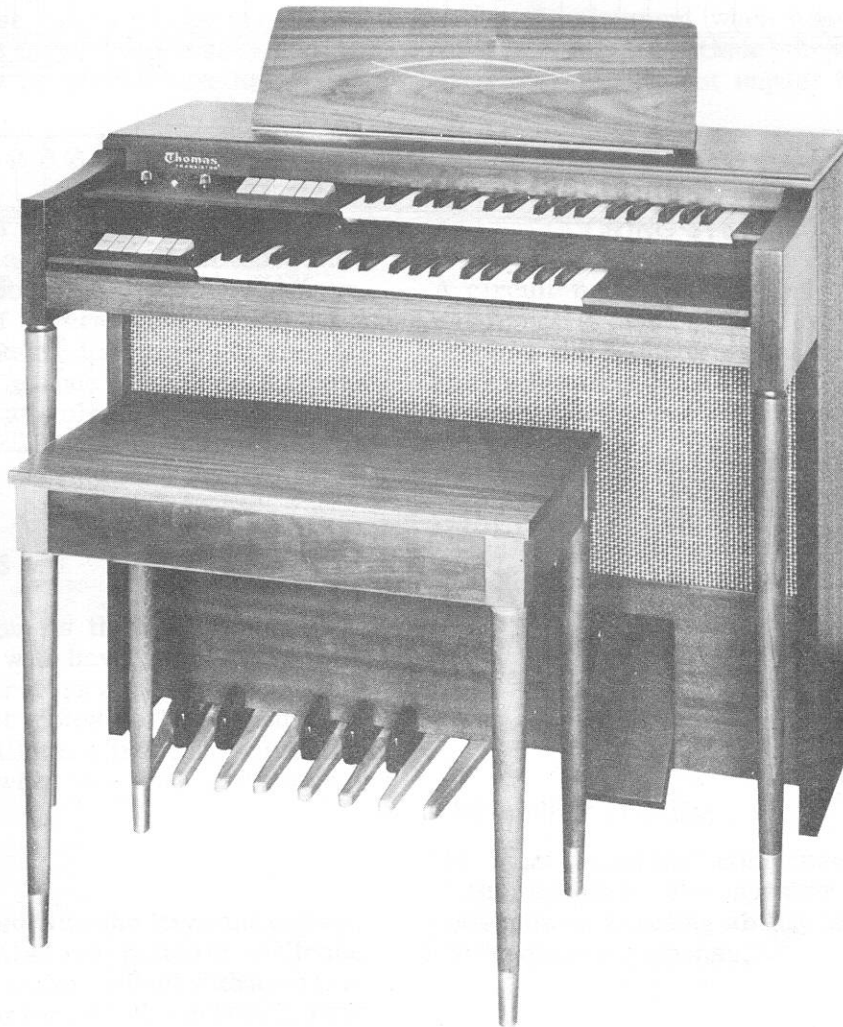

HEATH COMPANY,  
BENTON HARBOR, MICHIGAN

 a subsidiary of  
**DAYSTROM, INCORPORATED**

596-652

PRINTED IN U. S. A.

6/14/63

## *Introduction*

Your new THOMAS-HEATHKIT Model GD-232 Transistor Electronic Organ is a high quality musical instrument designed for home, apartment, chapel, or school use.

The Organ has two 37-note (3 octaves) keyboards which range from C2 through C5. The keyboards are arranged to conform with standard organ specifications. The thirteen bass notes are arranged so you can use the heel and toe method of playing. There are ten organ voice switches. These voices can be played one at a time, to produce the effect of a solo-instrument, or many may be played together as an orchestral ensemble.

A total of sixty-five silicon transistors are used in the Organ. The tone generators and divider circuits are completely transistorized for long life, clear tone, and service-free operation. This results in low heat and freedom from hum and microphonics.

The cabinet is handcrafted from selected walnut veneers with solid hardwood used at all points which require extra strength and rigidity.

Your THOMAS-HEATHKIT Organ will provide years of enjoyment when assembled and operated properly. Continue through this manual carefully, and do not unpack the kit parts until instructed to do so.

## **ELECTRONIC ORGANS**

An electronic organ is a polyphonic musical instrument. This means that several tones may be sounded simultaneously. The electronic organ is usually made up of several different sections so that it can reproduce its variety of sounds. These sections are: a tone generator system; a keying system; a volume controlling or expression system; a tone coloring system; an amplifying system; a radiating system; and vibrato.

### **TONE GENERATORS**

The heart of an organ is the tone generators. A polyphonic organ will have twelve tone generators. These generators are very accurately tuned to the highest notes to be played. The remainder of the oscillators (frequency dividers) are synchronized with the tone generator.

### **KEYING SYSTEM**

The tones are selected with the keys and pedals. The keys and pedals are actually switches which, when pressed make contact with a certain tone generator and/or tone divider network. This completes the circuit and the tone is heard.

### **EXPRESSION SYSTEM**

A swell or expression pedal, through linkage, operates a volume control. This control is placed in the signal path to control the overall volume of the organ.

### **TONE COLORING SYSTEM**

A circuit must be provided to modify the harmonic structure of the keyboard signals to produce the various organ voices. These circuits are made up of electronic filters to modify the harmonic content of the signals.

### **AMPLIFYING SYSTEM**

The signal from the keys needs an amplifier to raise the power level to drive the speaker. The amplifier must have excellent bass power response and low distortion.

### **RADIATING SYSTEM**

The most important component in this system is the speaker. The speaker must have adequate power handling ability and have excellent low frequency response.

### **VIBRATO**

Vibrato is the variation of pitch of a tone. This usually takes place at a rate from 5 to 8 cycles per second. It is deliberately employed by many singers and musicians to add interest and color to the music.

# Specifications

Keyboards. . . . .	Swell manual: 37 notes, C2 through C5 (3 octaves). Great manual: 37 notes, C2 through C5 (3 octaves). Pedals: 13 notes, C1 through C2 (1 octave).
Voices. . . . .	Swell manual: Trombone, Reed, Flute, Oboe, Cornet, Violin. Great manual: Saxophone, Horn, Viola, Diapason. Bass pedals: Diapason.
Controls. . . . .	Pedal Volume and Organ on-off switch. Manual Balance, allows adjustment of the relative volume of either manual. Expression Pedal, allows adjustment of Organ volume. Vibrato, on-off. Vibrato, Full-medium.
Tone Generators. . . . .	12 transistorized master oscillators, C#4 through C5; twelve transistors.  25 transistorized bistable dividers, C2 through C4; fifty transistors.  Pulse amplifier and divider for pedal clavier, C1 through C2; three transistors.
Power Amplifier. . . . .	10 watts (20 watts peak power ). Tubes: 1 - 6CA4, rectifier. 1 - 12AT7, phase splitter and vibrato oscillator. 1 - 12AX7, amplifier. 2 - 6GK6, push-pull power output.  Amplifier also provides 15 volts DC and vibrato voltage to tone generators.
Speaker. . . . .	12", permanent magnet type.
Power Requirements. . . . .	105-125 volts AC, 60 cps at 70 watts.
Cabinet. . . . .	Genuine walnut finish, with solid hardwood used at all points which require extra strength and rigidity.
Size. . . . .	Overall: 41-1/4" high x 39-3/4" wide x 21-1/2" deep.
Net Weight (less bench). . . . .	117 lbs.
Shipping Weight	
Electronics. . . . .	78 lbs.
Cabinet. . . . .	83 lbs.
Bench. . . . .	17 lbs.

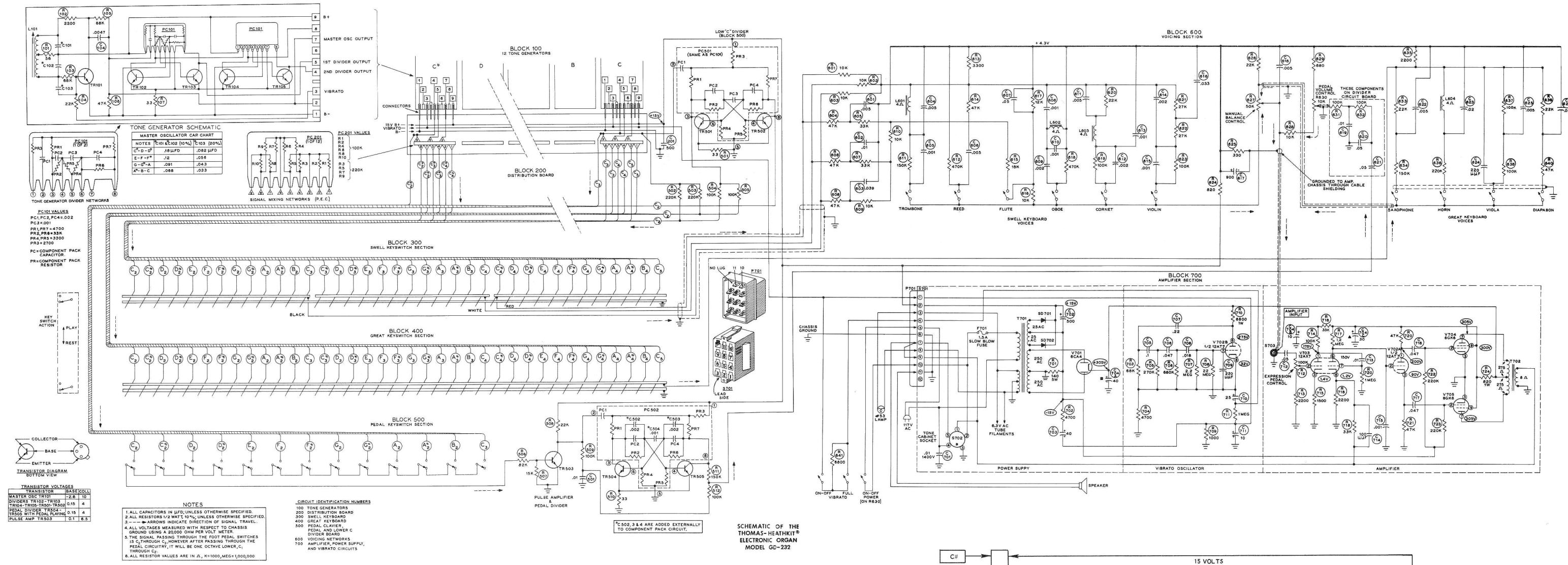

**SCHEMATIC OF THE THOMAS-HEATHKIT® ELECTRONIC ORGAN MODEL GD-232**

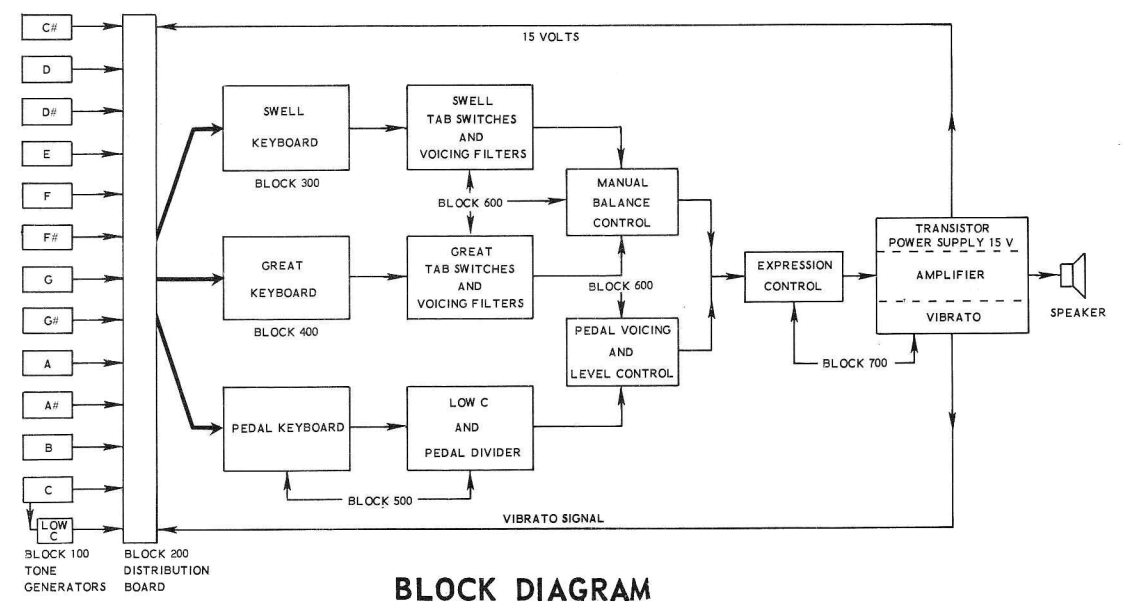

[Back cover blank page]