



RF



ORANGE COUNTY AMATEUR RADIO CLUB, INC.

VOL. LXV NO. 3

PO Box 3454, Tustin, CA 92781

March 2024

The Prez Sez...

By Nicholas AF6CF



We are in March already, and we have some sad news for our Club members and the radio community in general. It's with a heavy heart that I have to announce the passing of two good friends of the Club, Gene KJ6OML and Bob Heil, K9EID, Gene was an enthusiastic supporter of the Club, attending meetings and always lending a helping hand to transport and setup towers and antennas for Field Day. Bob was a celebrity not only in the Radio world, but was well known by the general public for his audio products. He gave speeches to our Club and I was always impressed by his humble demeanor and high energy.

This month's speaker will talk about Electromagnetic Recycling. (A.K.A. Frequency Re-use) where the same frequencies can be used more than once, which is an interesting topic.

Field Day preparations are under way, with the new Chairman Ron W6WG with meetings and ideas planned. Food is being planned (feed them and they will come) and a GOTA station for those not scheduled to operate or non licensed family members and visitors. We have several positions to be filled with Band and Food captains. A few are still open, so hurry up to volunteer. The FD Site is secured and my prediction is that we will have a great time - with or without propagation.

Several members plan to participate in the Baker to Vegas race communications support, Visalia DX Convention and other radio related events.

We will be really busy this year with all this and more activities. I look forward to an eyeball contact with you all at the next General Meeting.

73 DE AF6CF

NEXT GENERAL MEETING

IN-PERSON

**Michael Scofield
N6OKG
presents**

**“Frequency Reuse Over
Terrain”**

**March 15th, 2024, at 7pm
at the**

**American Red
Cross**

**Orange County Chapter
Santa Ana, Room 208**

NEXT BOARD MEETING

Saturday, April 6th, 2024

See www.w6ze.org for more info

In This Issue

The Prez Sez	1
Club Information	2
Speaker Spotlight Michael N6OKG	3
RadioActivity	4
Dues are Due	5
In the Know by KN6WNO	6-7
Heathkit Article – CW Keyer	8-17
Board Meeting Minutes	18-19
General Meeting Minutes	19-20
DX Convention Info	21
SBMS Special Meeting	22
Cash Flow Report Mar 2024	23



2024 Board of Directors

President

Nicholas Haban, AF6CF
(714) 693-9778
af6cf@w6ze.org

Vice President

Janet Margelli, KL7MF
(714) 600-6988
kl7mf@w6ze.org

Secretary

Tim Millard, N6TMT
(714) 744-8909
n6tmt@w6ze.org

Treasurer

Tim Goepfinger, N6GP
(714) 730-0395
n6gp@w6ze.org

Activities

Available
Your name here
info@w6ze.org

Publicity

AJ Ricci, KN6WNO
(714) 788-0847
kn6wno@w6ze.org

Technical

Ron Mudry, W6WG
(714) 840-3613
w6wg@w6ze.org

Membership

Corey Miller, KE6YHX
(714) 322-0395
ke6yhx@w6ze.org

Directors-at-Large:

Ken Konechy, W6HHC
(714) 348-1636
w6hhc@w6ze.org

Directors-at-Large

Joe Rodman, KM6SVV
(714) 454-5721
km6svv@w6ze.org

2024 Club Appointments

W6ZE Club License Trustee

Bob Eckweiler, AF6C
(714) 639-5074
af6c@w6ze.org

Club Historian

Corey Miller, KE6YHX
(714) 639-5475
ke6yhx@w6ze.org

RF Managing Editor

Corey Miller, KE6YHX
(714) 322-0395
ke6yhx@w6ze.org

RF Editor for March 2024

Tim Goepfinger, N6GP
(714) 573-8025
n6gp@w6ze.org

Webmaster

Dan Violette, KI6X
(714) 637-4632
ki6x@w6ze.org

Web Main Programmer

Bob Eckweiler, AF6C
(714) 639-5074
af6c@w6ze.org

Assistant Web Maintenance

Tim Millard, N6TMT
(714) 744-8909
n6tmt@w6ze.org

ARRL Awards Appointees

Arnie Shatz, N6HC
(714) 573-2965
n6hc@w6ze.org

John Schroeder, N6QQ
(West Orange Co.)
(562) 404-1112
n6qq@w6ze.org

Monthly Events

Membership Meetings*

Time: 7:00 PM
When: 3rd Friday of each Month
Red Cross Orange County, Room 208
600 N Parkcenter Dr, Santa Ana
(Replaced by the Christmas Party
in December.)

Board Meetings

First Saturday of each Month
*Board will handle Club business now
IN-PERSON.*

Club Nets (Listen for W6ZE)

10M ~ 28.375 MHz SSB

Wed- 7:30 PM - 8:30 PM
Net Control: Corey, KE6YHX
Alternate Net Control: AJ, KN6WNO

2M ~ 146.55 MHz Simplex FM

Wed- 8:30 PM - 9:00 PM
Net Control: Corey, KE6YHX
Alternate Net Control: AJ, KN6WNO
Echolink Node: KK6TRC-L

75M ~ 3.883 MHz LSB

Tue @ 8:00 PM
Net Control: Corey, KE6YHX

Other Nets

**Catalina Amateur
Repeater Association (CARA)**
147.090 MHz (+0.600 MHz) No PL
Monday - Friday
9:00AM & 9:00PM
Prg. Director. Tom W6ETC
COME JOIN US

OCARC 2024 DUES:

*Membership period is:
1 January to 31 December*

Individual New or Renewal: \$30
Family New or Renewal: \$45
Teen New or Renewal: \$15

New Member Dues are prorated
quarterly and includes a badge:
Additional Badges¹ \$3

Use one of our interactive online forms
to calculate current prices, join, renew, or
order badges:

<https://www.w6ze.org/FormsShortcut.html>

¹ \$3 or less + mailing. See form.

Speaker Spotlight Michael Scofield, N6OKG



Topic: Frequency Reuse Over Terrain

Frequency reuse is a technique for using a specified range of frequencies more than once in the same radio system so that the total capacity of the system is increased without increasing its allocated bandwidth.

The electromagnetic spectrum is a limited resource, so channels in both AM radio and VHF and UHF communications must be shared by various users. But, how closely? We will look at how the curvature of the earth helps by diminishing signal strength over distance. This is particularly true in aviation radio communication. We'll survey some tower frequencies back during

WWII, and perhaps get a laugh at what bands they used back then.

Michael Scofield, N6OKG, is an assistant professor at Loma Linda University. For over 20 years he was an assistant emergency coordinator for the Orange County Hospital Disaster Communications function of ARES. In that capacity he participated in or coordinated numerous member responses to general hospital emergency and mass casualty incidents. He has lectured to numerous amateur radio clubs for the past 30 years, and we are lucky to have him add our club to the list this month.

Please join us Friday, March 15, at 7PM at the American Red Cross, [600 Parkcenter Drive, Room 208, Santa Ana](#), and learn how signals that use the same frequencies stay sufficiently isolated. See you there!

Janet Margelli, KL7MF
W6ZE/OCARC Vice President



RadioActivity

March 2024

Upcoming Activities:

MARCH

- **Russian DX Contest:** 1200 UTC Saturday March 16 through 1200 UTC Sunday March 17
- ***CQ WW WPX / SSB:** 0000 UTC Saturday March 30 through 2359 UTC Sunday March 31

APRIL

- **JI CW Contest:** 0700 UTC April 13 to 01300 UTC April 14
- **Holyland DX Contest, SSB & CW:** 2100 UTC April 19 to 2059 UTC April 20
- **ARRL Rookie Roundup, SSB:** 1800 UTC to 2359 UTC April 21
- **10-10 Int. Spring Contest, Digital:** 0001 UTC April 27 to 2359 UTC April 28

* Indicates club entries are accepted

** Indicates team entries are accepted

State QSO Parties:

- **Virginia QSO Party:** 1400 UTC Saturday March 16 to 0400 UTC Sunday March 17 and 1200 to 2400 Sunday March 17
- **Louisiana QSO Party:** 1400 UTC April 6 to 0200 UTC Sunday April 7
- **Mississippi QSO Party:** 1400 UTC April 6 to 0200 UTC Sunday April 7
- **New Mexico QSO Party:** 1400 UTC April 13 to 0200 UTC Sunday April 14
- **Georgia QSO Party:** 1800 UTC April 13 to 0359 UTC April 14 and 1400 UTC to 2359 UTC Sunday April 14
- **Nebraska QSO Party:** 1100 UTC Saturday April 20 to 2259 Sunday April 21
- **North Dakota QSO Party:** 1800 UTC Saturday April 20 to 1800 UTC April 21

Repeating Activities:

- **Phone Fry:** Every Tuesday night at 0230Z to 0300Z
- **SKCC:** Weekend Sprintathon (Straight Key CW) on the first weekend of the month after the 6TH of the month. 1200 Sat. to 2359Z Sunday.
- **SKCC:** Sprint (Straight Key CW) 0000Z to 0200Z on the 4th Tuesday night (USA) of the month.
- **CWops:** Every Wednesday 1300 UTC to 1400 UTC 1900 UTC to 2000 UTC and Thursday 0300 UTC to 0400 UTC
- **ICWC Medium Speed Test:** (CW, 25WPM Max.) Every Monday 1300 UTC to 1400 UTC 1900 UTC to 2000 UTC and Tuesday 0300 UTC to 0400 UTC
- **K1USN Slow Speed Test:** (CW, 20WPM Max.) Every Friday 2000 UTC to 2100 UTC Every Sunday night at 0000 UTC to 0100 UTC Monday

OCARC Club Nets:

- **10 Meter Net:** Every Wednesday night at 7:30 pm to 8:30 pm Local Time. SSB 28.375 MHz
- **2 Meter Net:** Every Wednesday night at 8:30 pm to 9:30 pm Local Time. FM Simplex 146.55 MHz

Other Nets:

- **Net-AT-9:** Wellness & Support
Monday thru Friday 9:00 am
and 9:00 pm Local Time
147.090 MHz (+600 MHz)
No PL

Send an email to *Ron W6WG*, w6wg@w6ze.org to have your favorite activity or your recent RadioActivity listed in next month's column.

2024 OCARC



You can see if you have renewed your membership by going to our Roster at [OCARC Roster](#), and if there is a check mark next to your name, you are paid up for 2024!

Our online renewal form is on our website here: [OCARC Online Renewal](#)

IN THE KNOW WITH KN6WNO

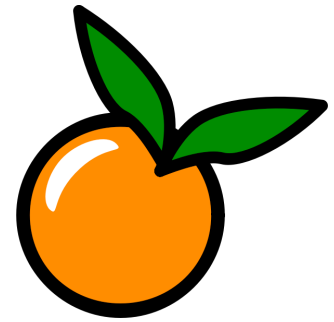

Issue 2



Consolidation

It has been almost 2 years since I've received my amateur license. Needless to say, I've started amassing connectors, wires, cords, coax, transceivers, screws, etc in this hobby. My QTH is in my 1902 barn/ garage in an old carriage room that's about 50 sq ft. While I have the rest of the garage and a hayloft for storage, I try to keep everything in one room. The process of acquiring gear is a right of passage for newer operators wanting to collect more specialized equipment for specific operating modes, which entails discovery, education, and personalization.

Seasoned hams have gone through this cycle, and for some are at a point in time where consolidation is becoming a practical necessity. Specifically those who are downsizing to retirement communities with covenants on external antennas. I take note of what items older hams part with first, as an assessment of what my priorities should be when organizing my own QTH. One of the first items tends to be connectors, grounding wire, and antenna parts.

Second to the previously mentioned items to go is handheld radios, amplifiers, and reference material such as antenna theory or ARRL® Handbooks. Paper reference material is becoming less of an issue as more technical references are put online.

So with this inferred priority list, I try to keep my handheld collection light and do not keep wires or connectors to equipment that I do not have. If I buy a new transceiver, it must have a unique feature or mode/capability that I previously did not have. Also, everything must fit or go into a drawer/box. I'm of the type where I cannot leave an open project on my workbench else I risk pieces to start missing.





GEAR REVIEW

The Kenwood TM-V71A~

At the time of this article, this radio can be found for sale between \$550 to \$700. Originally released June 2007, this is a dynamite radio. I have gone through two 2m/70cm 50 Watt mobile type radios, and this one is one that will last a ham's lifetime on 2m/70cm. This radio has a max output of 50 Watts. One thing that drew me to this radio is the backlight dualband front display with interchangeable colors. Too many new radios have glaringly bright screens as compared to the soft backlight and the choice of amber or green for the LCD screen. The front display is detachable and can be mounted in a number of mobile configurations. Additionally, you can program every feature of this radio from the front panel, with the exception of specific EchoLink© features. There is also a serial port on the rear of the radio that can be utilized for serial drivers and digital modes. On the back you have two mono outputs for Channel A/B. One of the best tactile features of this radio is the 2 dials on the right hand side that act as channel selection, independent volume and squelch control. This is a satisfying radio to save all your favorite repeaters or calling frequencies, leaving one side on Channel Seek, and leaving the other on VFO mode and relaxing in your QTH.



Heathkit of the Month #121:
by *Bob Eckweiler, AF6C*



AMATEUR RADIO - SWL

**Heathkit HD-10
Electronic Keyer**

Introduction:

In very late 1965 or early 1966 Heathkit introduced the HD-10 Electronic Keyer. It is not listed in the main 1966 catalog, which is usually released late in the third-quarter of the prior year. The HD-10 sold for \$39.95 throughout its lifetime and was discontinued in the second half of 1974. In 1975 Heathkit introduced its replacement, the HD-1410, which was introduced at \$59.95.

The HD-10 Electronic Keyer:

The HD-10 (**Figure 1**) is all solid-state, using eleven transistors and seven diodes. It does not use any integrated circuits, which were just coming onto the market about that time.

Table I lists the semiconductors. Sometime during production, Heath switched from the 2N407 to the 2N408 transistor¹.

The HD-10 is designed for use with transmitters using grid-block keying only, though there are modifications to allow positive voltage keying². The HW-16, SB-110, SB-400 and DX-60A radios Heathkit was selling at the time, all use grid-block keying.

Here is a link to the index of Heathkit of the Month (HotM) articles:

http://www.w6ze.org/Heathkit/Heathkit_Index.html

1. Notes begin on page 17



Figure 1: My recently acquired HD-10 Electronic Keyer.

The HD-10 has a built-in paddle. It is not iambic, but it may be used either as an automatic keyer, where both dits and dahs³ are created electronically, or where dits are automatic and the dahs are manual, similar to using a Vibroplex bug. The paddle may be wired for right or left handed people. Switching between them requires heating up the soldering iron and swapping a couple of internal wires as well as reversing the knobs on the keying paddle.

While primarily designed to run off 115 vac line voltage, the HD-10 can be run from batteries. Either a 45 V dry cell battery with a

HEATHKIT HD-10 SEMICONDUCTORS

Qty	Type	Heath #	Description
5	1N191	56-26	Ge Crystal Diode
2	CER100	57-29	Si Rectifier Diode
OR	1N4002	57-65	Si Rectifier Diode
1	2N398A	417-43	Ge PNP HV Transistor
7	2N407	417-28	Ge PNP Transistor
OR	2N408	417-18	Ge PNP Transistor
3	2N2712	417-67	Si NPN Transistor

Ge - Germanium Technology.

Si - Silicon Technology

TABLE I

22½ V tap (Burgess 5308, RCA VS-112, etc.) or two 22½ V dry cell batteries. Unfortunately these batteries have become expensive and not readily available in today's marketplace. In the manual, a scheme is given to power the HD-10 from 230 vac line voltage by installing a 0.068 µfd 600 volt capacitor in series with one lead of the power line cord ⁴.

The builder has a choice of two speed ranges depending upon which components are installed during assembly. Either 10 to 20 WPM or 15 to 60 WPM can be wired with the components supplied. ⁵

The HD-10 Controls & Connections:

The HD 10 measures 3¾" W. 4¼" H x 10½"D with a sloping top panel. On the sloping panel, at the top, is a 2.6" speaker. Below it are two potentiometers, side by side. The left potentiometer sets the speed and the right one sets the volume. The speed potentiometer is a dual-clutched potentiometer; the inner potentiometer moves with the outer one but can be adjusted separately with a screwdriver through a hole in the top of the knob. This adjustment allows setting the dot-to-space ratio. Below the potentiometers is a neon pilot light indicating the keyer is powered. The

pilot light remains off when operating from batteries. Below the pilot lamp is a three-position slide switch. **OFF** is to the left, the second position is **OPeRate** and the third is **HOLD**. HOLD closes the keying-line for the purpose of tuning up or making other observations or adjustments.

The keying paddle extends from the front of the unit, and on the back (**Figure 2**) is an eight screw terminal strip. The two mounting studs hold knurled nuts for grounding. The terminal strip provides connection for the keying-line, battery connections, external paddle, and more. Also on the back is a ¼" phone jack for earphones, and a grommet for the two-conductor line cord to exit.

The HD-10 Paddle:

The paddle mechanism mounts on a heavy ballast plate. Its weight, along with the steel chassis, and large rubber feet, keep the keyer from moving on the desk when sending code. The key lever (arm) uses a spring hinge mounted to a switch bracket bolted to the



Figure 2: Rear panel of the HD-10 Keyer showing the eight screw terminal strip. The two thumb-nuts on the mounting studs are grounds. Also shown are the phones jack and line cord exit.

ballast plate. Two leaf-springs and a shoulder spacer keep the key lever centered when in the neutral position. Switching is done by two microswitches, one activated when the key lever is moved to the left and the other when it is moved to the right. The HD-10 manual spends three pages on how to align the keyer arm and switches. Still when aligned correctly the paddle must move slightly less than 3/16" in either direction when sending. Neither of two reviews of the HD-10 ⁶ commented on this, but one wrote: *The built-in paddle is simple and ingenious and more than adequate for keyer beginners. Once you've become skillful, you'll probably*

want to switch to a paddle that has more precise action and is easily adjusted. Thinking ahead, Heath has provided for attaching an external paddle to the rear panel.

HD-10 Assembly:

The HD-10 could be called a "two-evening kit", a guide later used in many Heathkit ads. An 'evening' probably assumes three to four hours, as a guess. Assembly is simplified by the use of a printed circuit board that holds a large majority of the components including the two transformers. The eleven transistors are socketed ⁷; they aren't subject to soldering heat. **Figure 3** shows the HD-10

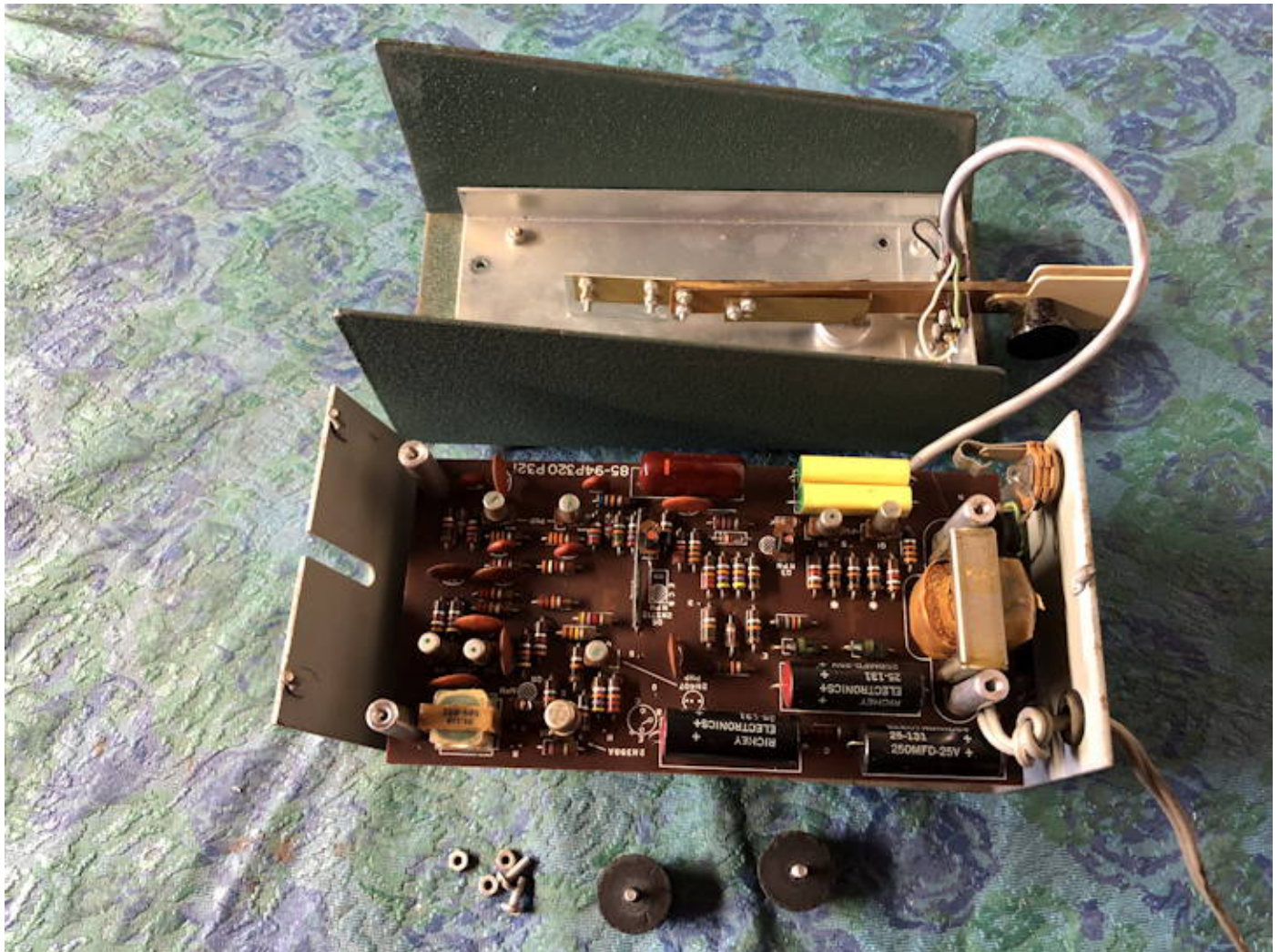

Figure 3: Internal view of the HD-10 with the cover removed showing the circuit board and keying mechanism. The power transformer is to the right and the smaller audio transformer is at the lower left.

cabinet open, revealing the circuit board as well as the keying mechanism. This keyer, being early production, uses the 2N407 transistors.

Final assembly of the HD-10 is a bit convoluted. The manual instructions, however, make it very clear how to proceed. The three assemblies (cabinet top assembly, circuit board assembly and cabinet bottom assembly) are laid on their left sides viewed from the front. The interconnecting cables, already attached, are dressed properly and then the circuit board is attached to the cabinet bottom assembly using 6-32 screws: $\frac{3}{8}$ " in the rear and $\frac{5}{8}$ " (through) feet in the front (See **Figure 4A** - Pictorial 11). The cabinet sections are then joined. Three 6-32 threaded studs are on the cabinet top. One is mated first with a notch at the rear cabinet bottom. The cabinet top is then lowered in an arc so the two front studs go into holes at the front of the cabinet bottom. The studs are then secured using #6 lockwashers and nuts (See **Figure 4B** - Pictorial 12).

If the cabinet needs to be reopened, do not follow the above procedure in reverse. The circuit board can easily be damaged by the phone jack, and wires can be pulled loose. In the manual Heath dedicates a short paragraph

Figure 4: Assembly and reopening of the HD-10 cabinet. These three illustrations are from the HD-10 manual [595-307]. **A:** shows how to align the assemblies before attaching the circuit board. **B:** shows how to joint the two cabinet assemblies. And **C:** shows how to properly reopen the cabinet.

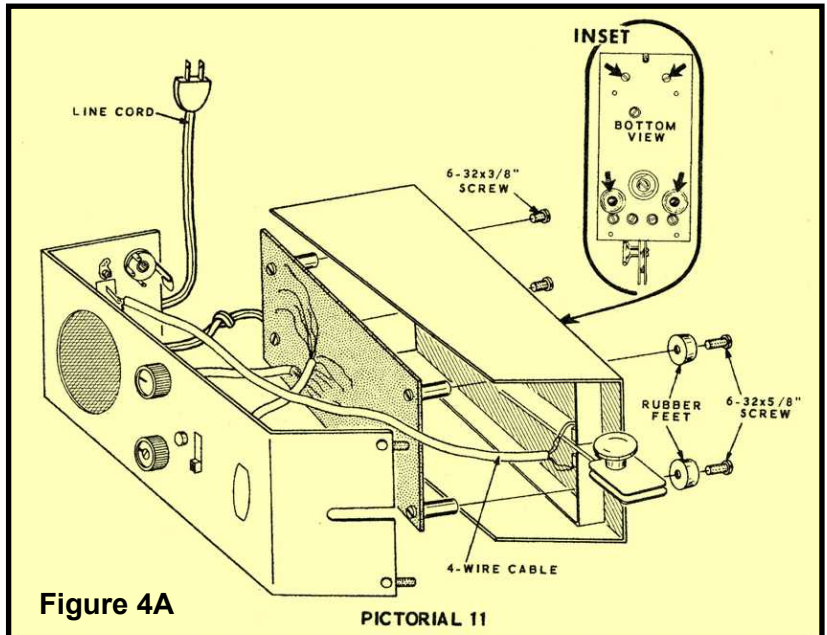

Figure 4A

PICTORIAL 11

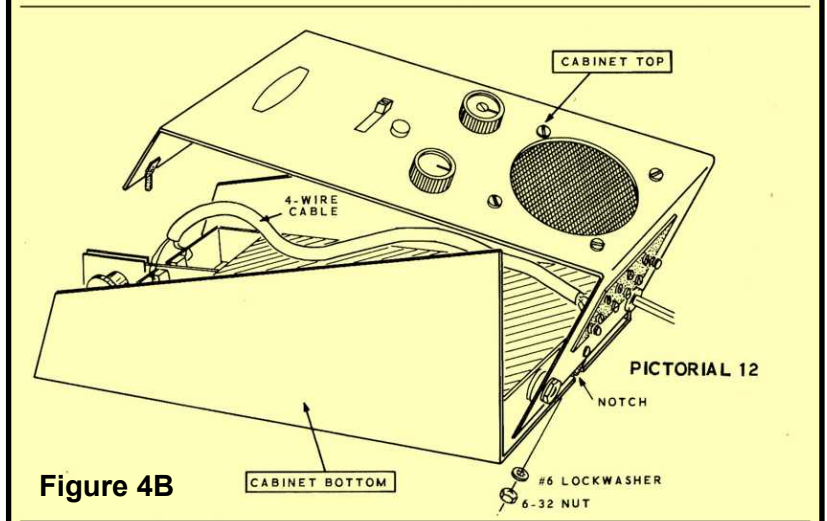

Figure 4B

PICTORIAL 12

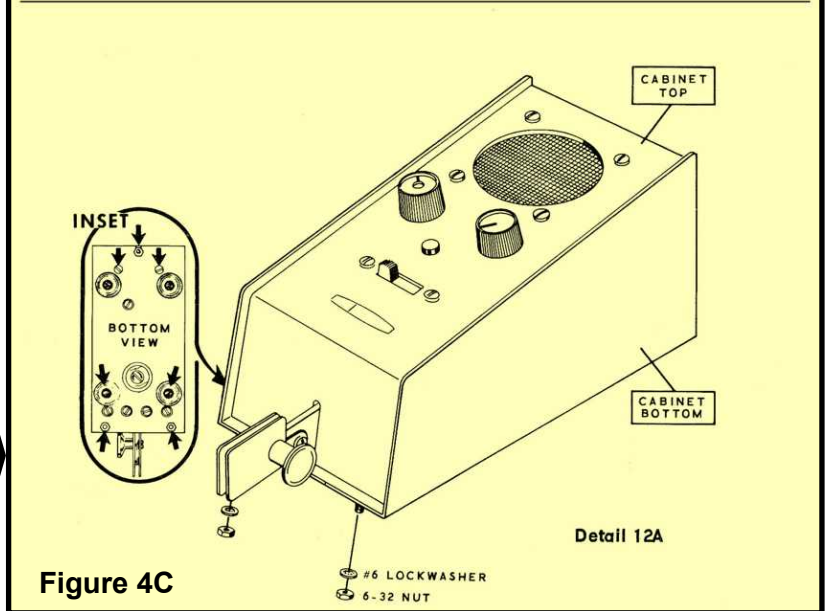

Figure 4C

Detail 12A

HEATHKIT HD-10 SPECIFICATIONS

KEYING:

Speed: 15 to over 60 WPM code group.
(Alternate connection for 10 to 20 WPM code group.)

Keying Output: Keyed line to chassis ground.

Voltage Polarity: Negative to ground only.

Maximum Open-Circuit or Spike Voltage: 105 volts.

Key-Closed Voltage: 0.2 volts maximum.

Key Closed Current: 35 milliamperes maximum.

GENERAL:

Audio: Internal speaker or high impedance headphone jack.

Transistor Complement:
7 2N407/2N408 PNP Germanium
3 2N2712 NPN Silicon
1 2N394A PNP Germanium.

Controls: Off-operate-hold switch.
Speed control.
Dot-to-Space ratio control.
Volume Control

Rear Panel Connections: Keyed line.
Receiver Audio.
Battery +45 volts.
Battery +22 ½ volts.
Hand key.
Dash arm.
Dash.
Dot.

Power Requirements: AC operation: 105 - 125 volts AC, 50 / 60 cps.
Battery operation: 45 volts with 22 ½ volts tap; 14 milliamperes.

Dimensions: 3 ¾" wide x 4 ¼" high x 10 ½" deep.
5 lbs.

TABLE II

on how to properly re-open the cabinet:

(√) *To open the cabinet, remove the nuts and screws indicated by the arrows in the inset drawing of Detail 12A. Then lift the cabinet top and circuit board out of the cabinet bottom.*

Detail 12A and the mentioned inset are shown in **Figure 4C**.

HD-10 Specifications & Circuit:

Table II lists the HD-10 specifications, from the manual. **Table III** lists the timing values for international Morse code.

Figure 5 is a block diagram of the HD-10 from the manual and **Figure 7** is the schematic. Often the circuit descriptions supplied in the Heathkit manuals are basic and lack a lot of detail. In the HotM articles an attempt is made to provide a more de-

Morse Code Timing Basics

The timing of an international Morse code sentence is based on the "T-Unit" which is the length of a dit in milliseconds (mS). Here are the defined lengths for other parts of the International Morse code:

Dit length:	1T (by definition)
Dah length:	3T
Intra-character space ^a :	1T
Inter-character space ^b :	3T
Inter-word space:	7T

^a The space between dits and dahs within a character.

^b The gap between the characters of a word.

Here are values of T for some common speeds:

5 WPM	240.0 mS.
10 WPM	120.0 mS.
13 WPM	92.3 mS.
18 WPM	66.7 mS.
20 WPM	60.0 mS.

Caution: These 'T' values are only good for determining WPM. A second code speed exists, 'code groups per minute' which have slightly different values for 'T'.

TABLE III

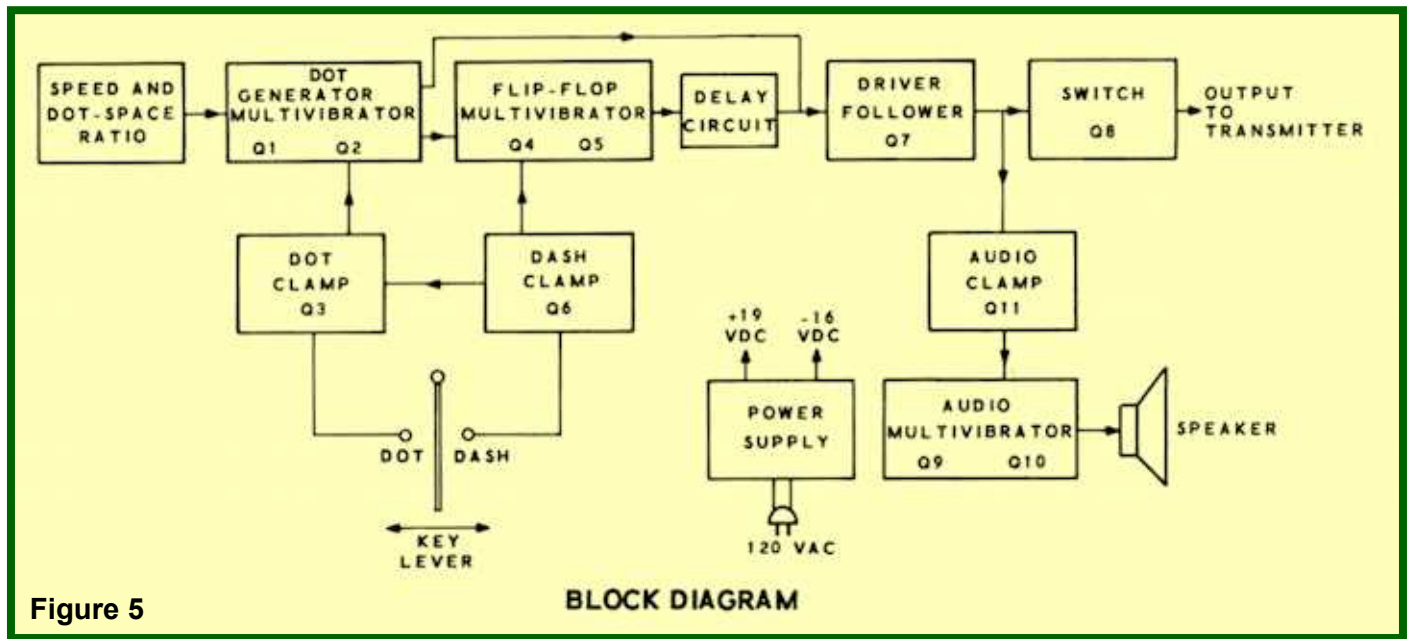

tailed description. However, the circuit description of the HD-10 is quite detailed, taking up six pages. And it would be redundant to go into too much detail. Thus a shortened description of the circuit follows:

The power supply is simply two half-wave rectifiers and filters producing +19 volts and -16 volts, both unregulated.

Three similar flip-flop circuits, each using two 2N407 or 2N408 transistors, and each controlled by a clamp transistor, make up a majority of the circuitry. Two of the flip-flops, the dot generator and the audio generator, are wired as multivibrators. With the key lever centered, clamp transistors Q3, Q6 and Q11 are conducting and hold the dot multivibrator, the dash flip-flop and the audio multivibrator in a defined initial state.

Dot Generation:

In the clamped state Q1 is conducting and Q2 is off. When the key lever is moved to the dot side S1 closes, turning off the clamp Q3. Q1 and Q2 immediately flip state, with the collector of Q1 going high, turning on Q7 and Q8 through R79. Q7 is wired as an emitter

follower, and turns on Q8, the keying-line. After a period of time set by C10, C20 R11, R12, R22 and the speed and dot-space ratio ganged controls, the dot generator will again switch states turning off Q7 and Q8. Should the lever remain in the dot position, the dot multivibrator will continue to switch on and off at the same period of time producing a string of dots at the output. When the lever is moved to center, S1 opens, but the collector of Q1 is also connected to the base of Q3 through R30, so the Q3 clamp won't start to conduct until the dot and following space are completed.

Dash Generation:

Q4 and Q5 make up the dash flip-flop. this flip-flop will remain in whatever state it is in (when not clamped) until a positive going pulse is applied to the base of the transistor that is conducting. The pulse will cause the flip flop to change state. In the clamped state Q4 is held off and Q5 is conducting due to the clamp transistor Q6. When the key lever is moved to the dash side S2 closes turning off the clamp Q6. At the same time, due to diode D1, it also turns off clamp Q3, turning

on the dot multivibrator. When the dot multivibrator turns on Q2 immediately switches on. The collector voltage goes from -16 to near zero volts. This is coupled through C41 and D40, producing a pulse at the base of Q4. It is also coupled through C51 and diode D50 producing a pulse at the base of Q5. The pulse causes the flip flop to change state. Q4 is now conducting and Q5 is off. When the dot generator completes the dot and following space, Q2 again switches on causing a pulse to the base of Q4 causing the flip-flop to again change state. When Q5 is off, Q7 is on. Thus Q7 is held on by both the dot multivibrator and flip-flop for the first $\frac{1}{3}$ of the dash, by just the flip-flop for the second $\frac{1}{3}$ of the dash and by the second dot of the dot multivibrator for the last $\frac{1}{3}$ of the dash. R70, R71, R72, C70 and C71 delay the arrival of the dash to Q7 slightly to overlap and prevent any glitch that may occur when Q5 is turning on and Q1 is turning off.

Figure 6 demonstrates the sending a dash. The horizontal axis is time and the distance between the vertical lines represents the length of a dot. A dash is considered to be the length of three dots and the space between dot generator and dash flip-flop signals mix at the base of Q7 to form a dash. The slope of the vertical lines have been exaggerated to better show the glitch that is created without the delay; in reality they are much steeper. The top trace is the dot generator signal to Q7; if sent alone it would produce two dots. The second trace is the output of the dash flip-flop sent to Q7, If sent alone it would send just two-thirds of a dash. The third trace is what happens when they both are

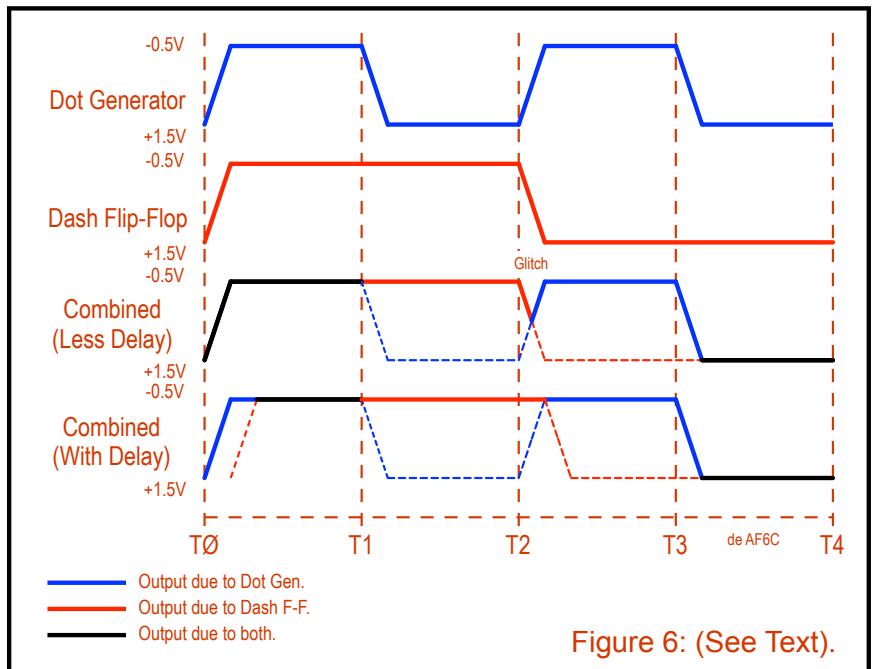
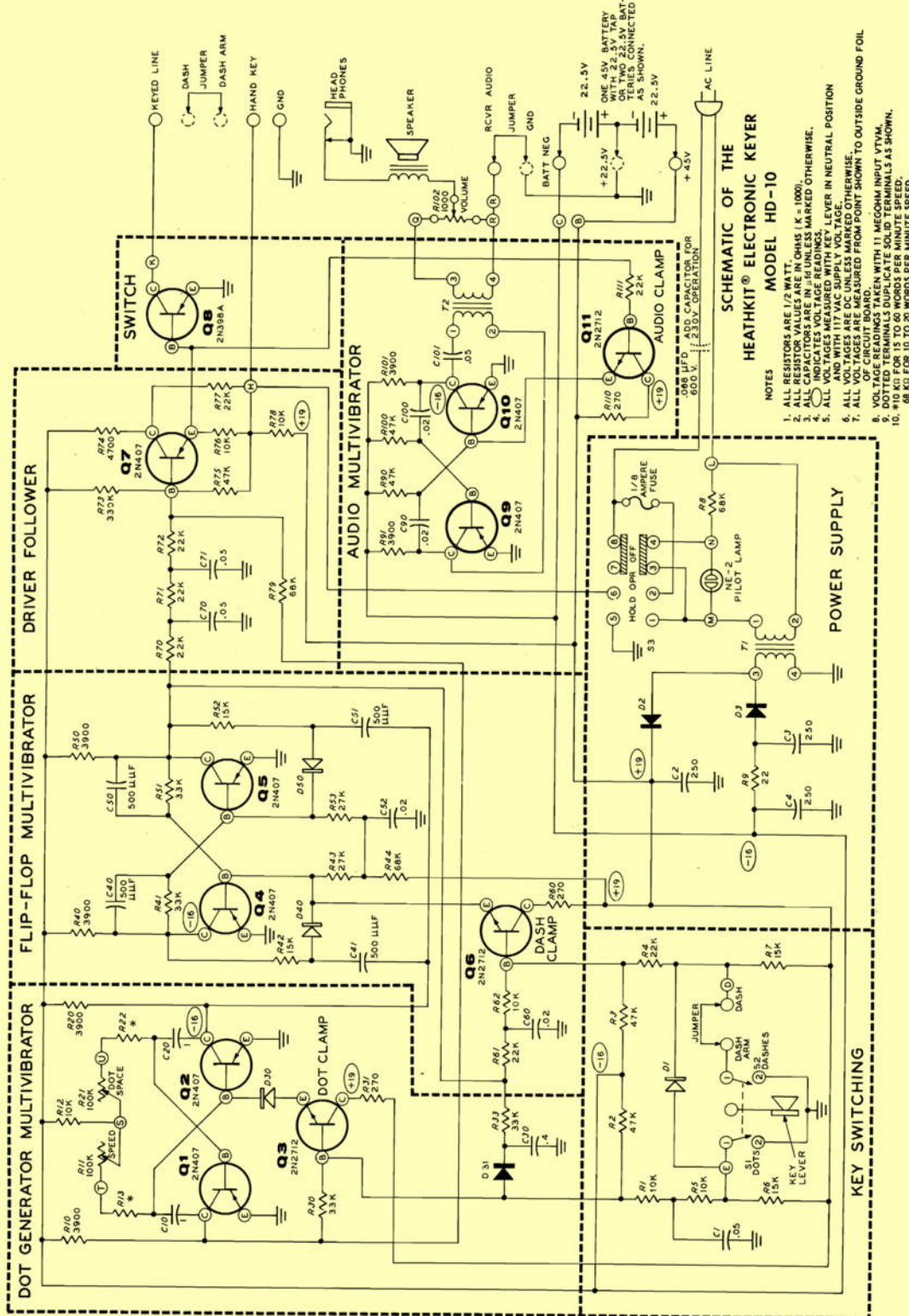

Figure 6: (See Text).

sent to Q7. You get a full dash; but there is a glitch that occurs when the flip-flop and dot generator swap levels. The fourth trace shows how delaying the arrival of the flip-flop signal by just a few microseconds resolves the glitch problem without affecting the dash shape.

Driver follower and Switch:

Q7 is normally biased into cut-off by resistors R73 to R76 and R78. The emitter of Q7 is at a positive 1.5 volts and is directly connected to Q8 Keeping it cutoff. Q8 gets its negative collector voltage externally from the device it is keying. The emitter of Q8 is grounded. When Q8 turns on it grounds the keying-line causing the transmitter to key. If an external hand key is attached to the HD-10 and closed, or if the function switch is set to HOLD, the junction of R75, R76, R77 and R78 is grounded, changing the bias on Q7 and causing it to conduct, turning on Q8. When Q1 turns off a negative 16 volts is fed through R79 to the base of Q7 turning it and Q8 on. Likewise, when Q5 turns off, a negative 16 volts is fed through the delay circuit



SCHEMATIC OF THE HEATHKIT® ELECTRONIC KEYSER MODEL HD-10

- NOTES
1. ALL RESISTORS ARE 1/2 WATT UNLESS MARKED OTHERWISE.
 2. ALL CAPACITORS ARE IN μF UNLESS MARKED OTHERWISE.
 3. ALL VOLTAGE READINGS ARE IN DC UNLESS MARKED OTHERWISE.
 4. ALL VOLTAGE READINGS ARE IN AC UNLESS MARKED OTHERWISE.
 5. ALL VOLTAGE READINGS ARE IN AC UNLESS MARKED OTHERWISE.
 6. ALL VOLTAGE READINGS ARE IN AC UNLESS MARKED OTHERWISE.
 7. ALL VOLTAGE READINGS ARE IN AC UNLESS MARKED OTHERWISE.
 8. VOLTAGE READINGS TAKEN WITH 11 MEGOHM INPUT VTVM.
 9. DOTTED TERMINALS DUPLICATE SOLID TERMINALS AS SHOWN.
 10. *10 KΩ FOR 15 TO 20 WORDS PER MINUTE SPEED.
 11. *10 KΩ FOR 10 TO 20 WORDS PER MINUTE SPEED.

FIGURE 7: Schematic of the HD-10 from the early [595-703] Manual.

to the base of Q7 turning it and Q8 on.

Audio Monitor:

Q9 and Q10 form the third flip-flop circuit; a multivibrator operating around 750 cps. Q11 is a clamp that keeps Q10 cutoff. When Q7 conducts its output is fed to Q11 starting the multivibrator. The resulting audio tone is coupled through T2 and the volume control to the speaker and phone jack. If earphones are being used, the audio from the receiver can be connected to the **RCVR AUDIO** input of the HD-10, so both can be heard in the earphones.

The HD-10 shown was purchased at a garage sale right before the pandemic. It sat until a month ago when it was put on the bench and found working with one minor problem the dot switch would often stick. It was put aside as other keyers are in use in the shack.

The Pickering K-1 Micro-Ultimatic Keyer:

In 1966 Tom Pickering - W1CFW published an article called the "Micro-Ultimatic ⁸", a digital iambic keyer using Fairchild RTL logic integrated circuits. I decided to build one, but instead of using 15 ⁹ epoxy pill style 8-lead ICs I used 7 Motorola 700 series 14 pin DIP style RTL ICs (2 MC724P quad, two input NAND gates; 3 MC790P dual JK flip-flops; and 2 MC792P triple, three input NAND gates.)

Tom Pickering later formed the Pickering Radio Company, selling an updated Micro-Ultimate key as the Pickering Radio Co. K-1, as well as code learning material and code practice tapes (**Figure 8**).

The Heathkit HD-1410 Keyer:

Heathkit missed the digital IC age with the HD-10 by a matter of months. For about 10 years, while the digital IC era expanded, Heathkit continued to profitably sell the

HD-10. Less than year after the HD-10 was discontinued, Heath introduced the digital HD-1410 Keyer; a keyer based on the TTL digital logic family. Perhaps the HD-1410 will be the topic of an HotM article in the near future?

Summary:

Heathkit introduced the HD-10 using discrete components. Even though the digital IC introduction quickly followed and, even though the keyer paddle was not ideal, Heath still sold a lot of these keyers. Reviews were good, You can often find the HD-10 at electronic swap-meets and garage sales.

I'm left-handed, and I've occasionally had to make a CW QSO at a friend's house using a bug or electronic keyer by turning it around and working it from the back. I've always wondered why there wasn't a simple switch on all keyers to change the key configuration. A simple DPDT slide switch is all that is re-



Figure 8: One of a set of three reel-to-reel code practice tapes sold by The Pickering Radio Company in the late 1960s.

quired. Some years back the group of Orange County (CA) amateur radio clubs sponsored a ham radio booth at the county fair. I forget the model of the keyer in use, but I did finally find how to switch it from right to left hand operation. One needed to go down numerous menus to do it. But there was no display so, without the manual, one would likely not succeed. Yes, I did set it back after I was finished – but I needed to refer to the manual again to do it!

HD-10 Changes Over Its Production Run:

Gerhard - DF1DA and Steve - N8FH, provided me different PDF versions of the HD-10 manual; 595-703 (3/25/1966) and 595-703-5 (undated - but close to the end of production). Cross-referencing the two parts lists showed a few changes. The OFF-OPR-HOLD switch changed from P/N 60-10 to P/N 60-22, though the new switch is physically close; the speaker P/N changed from 401-84 to 401-118, both 2.6" dia. and 100 Ω impedance, but with a significant change in cost; the neon pilot light changed from a sealed assembly (412-13) to an NE-2E (412-36) and a (413-10) red lens; the two rectifier diodes changed from a CER100 (57-29) to a 1N4002 (57-65); and, as mentioned earlier, the 2N407 transistors were changed to 2N408. One other change occurred; the 3 four-pin transistor sockets (434-101) were removed from the parts list and the 3 silicon 2N2712 transistors were soldered directly to the circuit board.

73, from AF6C



Notes:

1. The 2N407 and 2N408 are identical electrically; they differ in style of case. Lead layout remains the same.
2. Positive Keying modifications (Note these mods are for the newer transistorized radios that normally key +12V to ground. They will not work on high voltage / current needed for cathode keying):
 - QST** Jul. 1978 (Hints and Kinks) p 34: *Positive Key Line and the HD-10 Keyer*. Norman Bradshaw - W8EEF.
 - Ham Radio** Nov. 1978 (The Ham Notebook) p 88: *Positive lead keying for the HD-10 Keyer*. Richard Jasper, W4VAF.
3. Dah is the sound made by a dash. Di is the sound made by a dot except when it ends the character; then it is a Dit. Thus the letter 'P' is Di Dah Dah Dit.
4. I'd recommend, if you decide to try this, you make sure the capacitor is in series with the hot lead. and house the capacitor in a small box with good strain relief.
5. For 10 - 20 WPM – R13 and R22 are 68 K Ω
For 15 - 60 WPM – R13 and R22 are 10 K Ω
6. Reviews of the HD-10 appeared in:
 - 73 Magazine** Mar. 1966 p 6: *The HD-10 Heathkit's New Electronic Keyer* – Mort Waters - W2JDL
 - QST** Jan. 1967 (Recent Equipment) p 45: *Heath HD-10 Keyer* – W1CER
7. In later production runs the germanium transistors are socketed and the 3 silicon 2N2712 are soldered on the printed circuit board.
8. **73 Magazine** Jun. 1966 p 50: *The Micro Ultimate - Integrated circuits in a high-performance electronic keyer* – Tom Pickering - W1CFW.
9. In the original article 13 Fairchild epoxy packaged 8-lead ICs were used. The circuit was later improved resulting in replacing four dual-NAND gates (two per package) with four triple NAND gates (one per package). The Motorola DIP package contains four dual NAND gates (MC-724) and three triple NAND gates (MC792). The two spare triple NAND gates were used elsewhere.

Remember, if you are getting rid of any old Heathkit Manuals or Catalogs, please pass them along to me for my research.

This article is Copyright 2024 R. Eckweiler, AF6C and The OCARC Inc.

Thanks - AF6C

**OCARC Board Meeting
Minutes
March 2, 2024**

OCARC Board Meeting Minutes for: March 2, 2024, The OCARC Board meeting was held at The Streamliner Lounge, 186 N. Atchison St., Orange, and called to order by President Nicholas Haban AF6CF at 8:15 am. A quorum of Board Members was in attendance.

President report: Visited the Vintage Computer Festival and was able to handout club brochures to some attendees. Also spoke regarding the passing of Bob Heil K9IED, a giant in the amateur radio community. Who visited our club in the past.

VP: Has speakers arranged through August.

Treasurer report –Cash Flow report for this year shows we are breaking even. Renewals are slightly ahead of last year at this time. USPS P.O. Box renewal charge is up to \$190 annually.

Publicity report – acquired a table runner with club logo.

Directors at Large – Ken – Cal State Fullerton professor looking for a morse code demo for Media History class. Tim G – N6GP will take part. Joe – still on the hunt for an Activities manager.

Newsletter Mar Tim N6GP, Apr Bob AF6C, May Ron W6WG

Speakers –

Mar - Michael Scofield N6OK how we communicate under stress – “Life Without Full Duplex”.

Apr – Dick Norton, N6AA ARRL Division Director.

May – Ron Wilcox, KF7ZN – “Visit to the Sun and the Ionosphere”.

Jun - Sean Kutzko, KX9X “Get Ready for Field Day”

Jul - Kevin Caramons – 12 Volt Power and Kevin Zanjani from Bioenno Power.

Aug – Bob Brehm, AK6R Palomar Engineers.

Field Day 2024 – Ron will lead us as this year’s FD Chairman. Just like Winter FD but will add food, publicity and GOTA station. Field Day flyer for HRO distribution.

Zoom - no change in status.

Drawing planned for March General meeting. AJ has picked up a number of prizes that will be used for the quarterly drawings. AJ has a POTA backpack system for Show & Tell at the March General meeting.

Monthly Planner still in testing.

New business

There is a potential to receive some donated items from a ham who is downsizing. More information will be made available when and if this occurs.

Bioenno Power has donated a battery, solar array, and controller system to the club.

Good of the Club

President announced that he will not be present at the May meetings due to travel plans.

VP will be away for the April Board meeting.

Technical – Ron proposed we should have a contest for QSO's over the year between the members of our club. Handicap system for those who have fewer years of experience.

Adjournment occurred around 9:46 am.

OCARC General Meeting Minutes February 16, 2024

President Nicholas Haban, AF6CF start the meeting promptly and proceeded with the Pledge of Allegiance followed by guest and visitor introductions. There was a moment of silence for Gene Eckert, KJ6OML who recently passed away. Gene and his wife June were the club's 2022 Good of the Club Award recipients.

Nicholas had a short Show & Tell item, which was a 1950's era Morse Code practice keyer which included a speaker and a lamp. The item was produced for Boy Scouts.

Our VP Janet KL7MF introduced this evening's speaker, Bodo Fritsche – DF8DX. Bodo is a well-known DX'er and works for Ampegon AG, a firm involved in radio broadcast equipment as well as other radio-frequency amplifiers, power systems for fusion reactors, particle accelerators, and medical images systems.

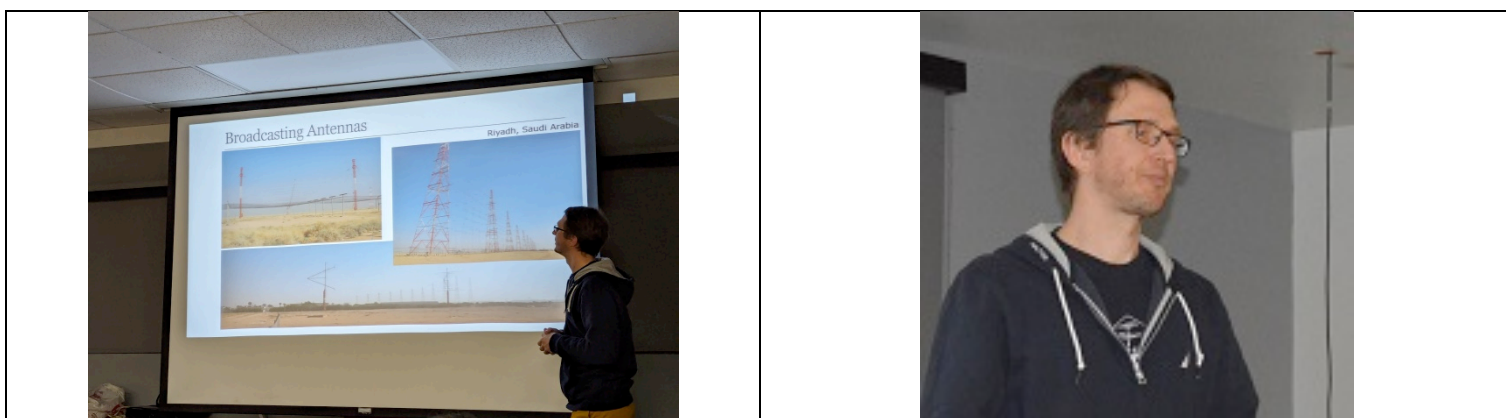

Presenter - Bodo Fritsche, DF8DX

After a short break the meeting continued with club business.

Board Meeting

A majority of board members were in attendance.

President Report – Winter Field Day was a successful activation with good attendance and many QSO's completed. Brian Turner was thanked for having a spare radio available when one of the planned rigs was faulty.

VP Report – next month's speaker is Michael Scofield, on managing communications in less than ideal conditions – "Life without Full Duplex."

June General Meeting is moved to the 2nd Friday, June 14th since the following weekend June 22nd - 23rd is Field Day.

Treasurer report - Membership renewals are being accepted currently.

Looking for Activities Director and a Field Day Chairman.

Show & Tell

Nicholas will be attending the Vintage Computer Show in Orange tomorrow and hopes to hand out Club Brochures to ham operators at the show.

The meeting was adjourned at this point.

Total Contacts by Band and Mode:

Band	CW	Phone	Dig	Total	%
80	20	1	2	23	1
40	204	183	1	388	15
20	354	684	1	1,039	39
15	392	404	1	797	30
10	103	296	1	400	15
6	1	1	0	2	0
2	1	1	0	2	0
1.25	0	1	0	1	0
70	0	1	0	1	0
33	0	1	0	1	0
23	0	1	0	1	0
13	0	1	0	1	0
9	0	1	0	1	0
6cm	0	1	0	1	0
3	0	1	0	1	0
Total	1,075	1,578	6	2,659	100

W6ZE WINTER FIELD DAY PRELIMINARY SCORES 2024

Score Statistics	
Total CW Contacts	1,075
Total Phone Contacts	1,578
Total DIG Contacts	6
Total Multipliers	27
Total Score	100,980



2024 International DX Convention at Visalia April 12-14 2024

<http://www.dxconvention.com/>

Hello Everyone!

The convention will be upon us very soon. So far we have \$50,000 in prizes committed, 25 major prizes and 45 hourly.

We have 15 confirmed exhibitors with more considering joining us! We also have 23, possibly 25 presentations! We are looking to opening a third room to run 3 tracks.

Here are two partial lists.

Prizes		Programs	
AG Custom Gifts	LED Displays	<u>DX</u>	
Alpha Radio	Rotators ?	TX5S Clipperton Island	
Array Solutions	3 ea. BAL5011L Baluns	W8S: Pileups from a private island in the South Pacific	
ARRL	2 ea. Gift Certificates	Andaman and Lakshadweep Dxpediton VU7A / VU4N	
Bioenno	2 ea. BLF-1220A+Charger 12 Volt 20 Amp Battery	Operating from China	
Bioenno	2 ea. BSP-100-LITE Solar Panel	CB0ZA Juan Fernandez	
Buckmaster	2 ea. HamCall DVD	KH8RRC Am. Samoa	
Daily DX	2 ea. Subscriptions	H40WA Temotu	
DX Engineering	2 ea. \$500 Gift Certificates	TJ9MD Cameroon	
Elecraft	K4D	CY0S Sable Island	
Flex Radio	Flex 4400M (TBD)	H44WA Solomon Islands	
Halibut Electronics	4 ea. Common Mode Current Choke Test Rig		
Halibut Electronics	HHi Contesting Console, Radio Pro + 2xUser Pro	<u>Technical</u>	
Ham Radio Deluxe	2 ea. HRD Program	Antenna Design	
Heil	Headsets (TBD)	Ground is a Myth	
Icom / HRO	2 ea. IC-7610 (TBD)	Cram Class Licensed... now what?	
Icom / HRO	2 ea. IC-7300 (TBD)	C-Match Phasing	
Island Amplifiers	\$500 Gift Certificate	Radio Design Technology	
JK Antennas	C3s-JK (TBD)	The Latest in SDR Technology	
MFJ	MFJ-2014 – Dual-Band OCFD Wire Antenna		
MFJ	MFJ-1703B – Switch ANT/XMTR Cross Over	<u>Interest</u>	
MFJ	MFJ-1701 – Antenna Switch, 6 Pos, 2kW	How Remote Operators can change the face of Dxpeditoning	
MFJ	MFJ-836 – RF In-Line Current/SWR/Wattmeter	The Storied History of DX	
Next Gen Antennas	Antenna (TBD)	The Role of the DX-pedition Pilot	
SEDXC	6 Books	K3LR Mega Station	
PhotoQSLs	4 ea, QSL Cards (250 Qty)	WSJT Dxpediton	
RadioSport	RS60CF		
RadioSport	RS20S Listen Only Headset		
The DX Store	2 ea. Rig Expert (TBD)		
The DX Store	Vertical Antenna		
US Towers	ALM-16		
Yaesu / HRO	2 ea. FTDX-101MP		
Yaesu / HRO	2 ea. FTDX-101D (TBD)		
Yaesu / HRO	4 ea. FTDX-10		
Yaesu / HRO	4 ea. FT-710		

Fundamentals of Vector Network Analysis



PRESENTED BY
COPPER MOUNTAIN
TECHNOLOGIES
FOR THE **SAN BERNADINO
MICROWAVE SOCIETY**

When:

May 2, 2024, 7:00 pm

Where:

American Legion Hall
1024 S. Main Street
Corona, CA

Why?

Find out how new VNA technology
meets amateur microwave needs

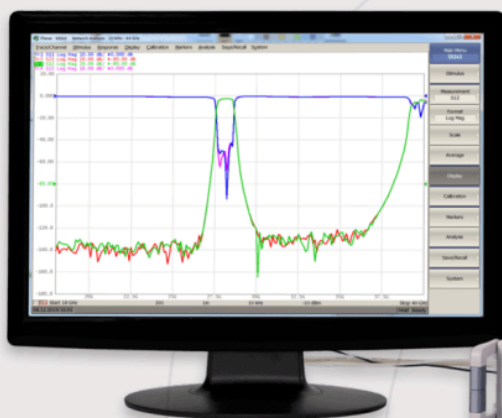

To join meeting via ZOOM use
this ID and passcode:

Meeting ID: 886 9217 9521

Passcode: 10368310

or this link:

<https://us02web.zoom.us/j/88692179521?pwd=MWwwM3NPejV2U3EyZXp2WXhQZnhVQT09>

Also on You tube under "Amateur
Television Network Live" and click
on "Live Now"

631 E. New York Street
Indianapolis, IN 46202

United States: +1.317.222.5400
Latin America: +1.954.706.5920

APAC: +65.63.23.6546
EMEA: +44 75 03 69 21 13

 WWW.COPPERMOUNTAINTECH.COM

Cash Flow - Year to Date

1/1/2024 through 3/1/2024

Category	1/1/2024- 3/1/2024
INFLOWS	
Dues, Membership (Paypal) 2024	538.46
Dues, Membership 2024	105.00
TOTAL INFLOWS	643.46
OUTFLOWS	
Flowers Expense	50.00
Guest Speaker Meal - Exp	86.00
Historian Expenses	74.24
PayPal Fee	25.68
Refreshments Expense	32.34
Web Site Hosting	50.00
WFD - Food	62.91
WFD - Propane	40.85
WFD Flowers	34.00
WFD Rental - Tent	170.00
TOTAL OUTFLOWS	626.02
OVERALL TOTAL	17.44

The **ORANGE COUNTY AMATEUR RADIO CLUB, INC.**

RF - VOLUME 65 ISSUE 3 - March 2024

P.O. BOX 3454

TUSTIN, CA 92781-3454



***First Class Mail
Time Dated Material.
Please Expedite!***

<https://www.w6ze.org>